

## FGV Series Digital Force Gauges Models FGV-0.5 — FGV-100

## Instruction Manual



### General Information

You have just received one of the world's smallest, rugged, economical and versatile force gauges; its ergonomic design makes this gauge a friendly instrument to the human hand. With just the touch of a button you can measure force in any engineering units desired, i.e. lbs, kgs or N. Any force from a few oz. up to 100 lbs can be accurately measured with one of the FGV family gauges. This series offers an RS232C and an analog output port for further processing the displayed measurements.

The unit's microprocessor enables it to measure forces very accurately in the "average" or "peak" mode. Its LCD display is smartly designed to inform the operator at all times of exactly what is going on.

If the hanger is used or the gauge is placed on a test stand, reversing the display so that it can be read right-side-up is simple: press only two buttons and the digits and units indicators reverse themselves instantly.

### Precautions

Do not use the gauge in hostile environments:

- A. High humidity areas
- B. High temperature environments  
(see specifications table)
- C. Caustic areas where various chemicals can seep into the unit.

When not in use, place gauge back in its case to prevent any damage due to an accidental drop etc. With a little care you can have an instrument that can last and provide service for many years.

### Operation

When the carrying case is opened make sure you have all the accessories that come with the instrument.

1. Charge the batteries for approx. 12 hrs. before using the gauge (batteries come discharged from the factory). When batteries are charging the BAT indicator is ON. When the batteries are fully charged the indicator goes OFF.
2. Hand tighten appropriate attachment to unit's measuring shaft (do not use a wrench or any other device to tighten the attachment).
3. Press the POWER switch and release. On the release of the switch the display will momentarily show all 8's (digit segment self-check) and then will show some zeros with the last one or two digits changing to some random numbers. Also the unit of measurement (lbs, kgs or N) will appear above the digits and stay as long as the instrument is on.

### Change Display Units

To change the display units, just press the UNIT button and the units will change every time this particular button is pressed.

## Reverse the Display

If unit is used with the hanger or mounted on a test stand and the display must be reversed, follow this procedure:

1. Press the POWER switch and hold it; display will go blank.
2. Press and hold UNIT switch.
3. Release POWER switch while you are still holding the UNIT switch; display is still blank.
4. Press the POWER switch once more and release it while still holding the UNIT switch. At this point you should see the display reversed.
5. Release the UNIT switch; the display stays in that mode.

If you want to go back to the normal mode, repeat steps 1 through 5.

## Select Average or Peak

If you want to measure force in real time (average) the display will show just the digits and units of the force being measured. If you want to measure "peak" force:

1. Press the PEAK button and the word PEAK will appear in the upper left corner of the display.
2. The display will freeze after capturing the peak force.
3. Press ZERO to cancel previous peak and continue with your tests.

If you want to go back to average mode press the PEAK button again and the word PEAK will disappear from the display.

**NOTE:** It is very important that you measure forces (tension or compression) that are in line with the measuring shaft and not at any angle (see fig. 1). Failure to observe this directive will damage the instrument. Also, after the gauge is positioned and ready to take a measurement (with the proper attachment in place) tare the unit by pressing the ZERO switch. In the PEAK mode to clear the display for another measurement, press the ZERO switch.

## Measure Tension

To measure tensile force use the hook attachment. The display will show the force measured and a minus sign (-) will appear on the left of the display (right next to the digits).

## Measure Compression

To measure compression force use the proper attachment. No sign will appear on the left of the display during a compression measurement.

## Low Battery

When the battery charge starts to get low, a LO BAT sign appears in the upper left corner of the display. At this point, if necessary, the adapter/charger can be used to power the unit indefinitely. With the power off it takes approx. 12 hrs. to fully charge. When the battery is fully charged the adapter/charger cuts off completely to protect the battery.

## Auto Power Off

If the power on the gauge is turned on and there is no activity for 10 minutes, the power is automatically cut-off to conserve battery charge. One minute before cut-off, the sign PWR appears above the display digits to remind the operator that there is 1 minute left before power cut-off. If the adapter/charger is powering the gauge, the Auto Power Cut-Off function becomes inactive.

## Tracking Function

A tracking function has been introduced to check and compensate for temperature drift. When measuring very minute forces (a few oz.) and at a very slow rate, you may want to turn off the tracking function. To turn the tracking function on or off, follow the steps below:

1. Turn POWER off.
2. Press PEAK and UNIT switches simultaneously and hold these until step 3 is complete.
3. Press POWER switch and release it to turn the power on. If tracking function was on, the display will show TRK OFF momentarily.
4. Release buttons PEAK & UNIT. The tracking function is now off. Repeat above steps to turn it on. It is a good idea to have this function on all the time unless it is absolutely necessary to cancel it.

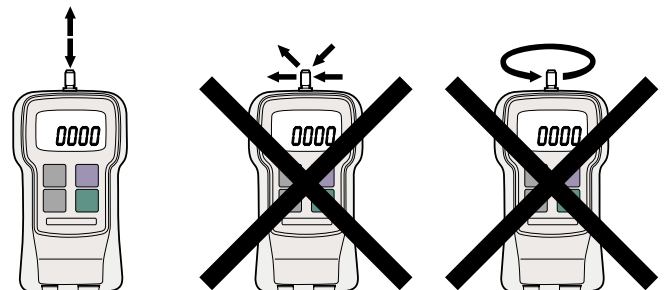
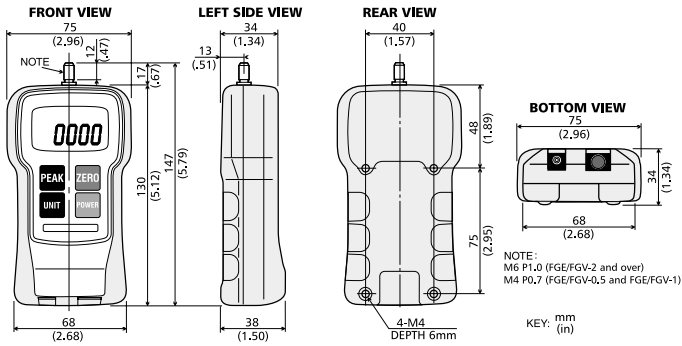

Fig. 1

## Dimensions



## Overload

Even though each model is able to withstand an overload of 200% of its rated capacity, caution should be exercised that this does not happen very often otherwise the sensor will be damaged. To protect the gauge and/or the sample under test when a motorized stand or some other motorized device is used in conjunction with the gauge, two overload output OC NPN transistors are available to be used to disconnect power when the overload condition reaches 120% of the gauge's rated capacity. One transistor is for tension and the other for compression. See diagram below (Fig 2).

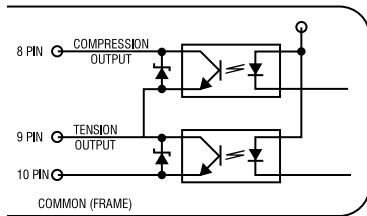

Fig. 2

## Analog Output

An analog output signal is available for recording purposes. The amplitude of this signal is  $\pm 1$  VDC. The voltage is positive when compression testing is performed and negative for tension.

### Signal Characteristics:

Amplitude:	$\pm 1$ VDC
Generated by:	12-bit D/A converter
Signal update:	140 times/sec
Load impedance:	10 K $\Omega$ minimum
Connector pins:	Pin #1 signal output (analog) Pin #2 GND (analog) (see Fig.3 & Table 1)

**NOTE:** When the zero switch is pressed to tare the gauge the analog output goes to 0V automatically.

## RS232C Port

The most important feature of the FGV family of gauges is the availability of the RS232C communications port. Data and commands can be linked to a PC or any other device responding to RS232C signals for storage or further analysis. Table 1 (below) describes the function of each pin of the connector (HR12-10RC-10SDL) shown in Fig. 3.

PIN#	DESCRIPTION
1	Analog signal output
2	Analog GND
3	Receive data (input)
4	Digital GND
5	Communication enable
6	Transmit data (output)
7	No connection
8	Compression overload output
9	Tension overload output
10	Frame GND

Table 1

### RS232C Output Specifications

Baud rate:	2400 bps
Data length:	8 bits
Parity:	None
Stop bit:	One
Logic level:	$\pm 10$ V

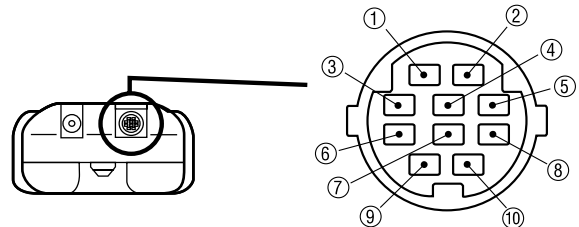

Fig. 3  
(HR12-10RC-10SDL), HIROSE

## Connections

FGV Output connector pin#	RS232C Connector on PC (D-sub 25pin)
3 (RxD)	2 (TxD)
6 (TxD)	3 (RxD)
4 (GND)	7 (GND)
5 (Enable)	4 (RTS) 5 (CTS)

# Commands/Responses

The FGV series of force gauges has the ability to recognize and respond to various commands from outside peripherals. If for instance the gauge receives a legitimate command from a PC, it will respond by sending back the same code indicating to the PC that the command was recognized. If for example the command is a request for average data output, it will send the data and the code NA etc. If the gauge recognizes an error while it is receiving a command, an error symbol is transmitted back to the PC indicating the exact nature of the error.

## Commands to FGV Gauge

AAcr:	Tare
ABcr:	Stop output
ACcr:	Change to peak mode
ADcr:	Change to average mode
AEcr:	Peak reset
AFcr:	Change units to kg (g)
AGcr:	Change units to N
AHcr:	Change units to lb (oz)
BAcr:	Data output request
BBcr:	Continuous data output request (10 times/sec)
BCcr:	Model name confirmation request
BDcr:	Units confirmation request
BEcr:	Peak data output request

## Response from FGV Gauge

NA□□□□□cr:	Average data output																
NB□□□□□cr:	Peak data output																
4-digit number with decimal point sign (+ or -)																	
NE□□□cr:	Model number																
<table border="1" style="display: inline-table; border-collapse: collapse;"> <tr><td>02</td><td>03</td><td>04</td><td>05</td><td>06</td><td>07</td><td>08</td><td>09</td></tr> <tr><td>FGV-0.5</td><td>FGV-1</td><td>FGV-2</td><td>FGV-5</td><td>FGV-10</td><td>FGV-20</td><td>FGV-50</td><td>FGV-100</td></tr> </table>		02	03	04	05	06	07	08	09	FGV-0.5	FGV-1	FGV-2	FGV-5	FGV-10	FGV-20	FGV-50	FGV-100
02	03	04	05	06	07	08	09										
FGV-0.5	FGV-1	FGV-2	FGV-5	FGV-10	FGV-20	FGV-50	FGV-100										
NH□□cr:	Unit																
<table border="1" style="display: inline-table; border-collapse: collapse;"> <tr><td>0</td><td>1</td><td>2</td></tr> <tr><td>N</td><td>Kg (g)</td><td>lb (oz)</td></tr> </table>		0	1	2	N	Kg (g)	lb (oz)										
0	1	2															
N	Kg (g)	lb (oz)															

## Error symbols:

OBcr:	Command error
ODcr:	Overload error
OEcr:	Parity error
OFcr:	Format error
OGcr:	Summing error
OHcr:	Overrun error

# Calibration

## Required for Calibration:

1. A secure calibration stand to mount a force gauge upside-down.
2. The appropriate calibration weight for your force gauge:

MODEL	WEIGHT	MODEL	WEIGHT
FGV-0.5	200g	FGV-10	5Kg
FGV-1	500g	FGV-20	10Kg
FGV-2	1Kg	FGV-50	20Kg
FGV-5	2Kg	FGV-100	50Kg

## Calibration Procedure:

1. Turn POWER off.
2. Mount the force gauge upside-down on the calibration stand.
3. Attach the hook on the sensing shaft of the force gauge.
4. Press and hold the UNIT, PEAK and ZERO switches.
5. Press and release the POWER switch (while continuing to press UNIT, PEAK and ZERO) until the smaller characters at the top area of the display show CAL. Release the UNIT, PEAK and ZERO switches. The force gauge is now in calibration mode.
6. Press the UNIT switch. The display will show ZER. The force gauge is now ready for zero point calibration.
7. Press ZERO to zero point calibrate. Wait 5 seconds. The display will change to show PEK. Do not press any other switches or move the sensing shaft during calibration.
8. Hang the calibration weight on the hook and stabilize; the larger characters on the display will change. The force gauge is now ready for full scale calibration.
9. Press the PEAK switch to begin full scale calibration. Do not press any other keys or touch the weight during calibration. After approximately 5 seconds the display will show END.
10. Press the UNIT switch. If calibration was successful, the display will show OK momentarily, then automatically power off. If calibration was unsuccessful, the display will show ERR. Remove the calibration weight and repeat the procedure from step 6.

# Specifications

MODELS	FGV-0.5	FGV-1	FGV-2	FGV-5	FGV-10	FGV-20	FGV-50	FGV-100
CAPACITY	8 oz 200 g	16 oz 500 g	2 lb 1000 g	5 lb 2 Kg	10 lb 5 Kg	20 lb 10 Kg	50 lb 20 Kg	100 lb 50 Kg
RESOLUTION	0.01 oz 0.001 N	0.001 lb 0.01 N	0.001 lb 0.01 N	0.001 lb 0.01 N	0.01 lb 0.1 N	0.01 lb 0.1 N	0.01 lb 0.1 N	0.1 lb 5.0 N
ACCURACY	±0.2% FS plus 1/2 digit at 73°F (23°C)							
DISPLAY	4-Digit LCD 12mm high. Reversible by a push of a button. Minus sign for tension.							
AVERAGE/PEAK MODE	Yes (selectable)							
LOW BATTERY INDICATION	Yes							
DISPLAY UPDATE	0.3 second							
SAMPLING RATE	35 times per second							
OVERLOAD	200% of FS							
POWER	Rechargeable Ni-Cad batteries or AC through adapter/charger							
OUTPUT	RS232C and ±1VDC (through a 12 bit D/A converter)							
AUTO POWER OFF	Yes (not active if adapter/charger is in use)							
BATTERY CHARGE	20 hrs. when fully charged							
RECHARGE TIME	12 hrs. approx.							
TEMPERATURE	32° - 104°F (0° - 40°C)							
DIMENSIONS	5.1"L x 2.9"W x 1.5"H (130 x 75 x 38)mm							
WEIGHT	1lb (450g)							
OVERLOAD OUTPUT	One NPN OC transistor for tension, one NPN OC transistor for compression							
ACCESSORIES (INCLUDED)	AC adapter/charger, carrying case, hook ,chisel, flat head, notched head, hanger, cone head, extension rod and analog output cable.							
ACCESSORIES AVAILABLE	Test stands, RS232C cable, overload cable.							