

OPTIONAL TERMINALS FOR PUSH ON OR SOLDER CONNECTIONS (.032 X .250) [0.8 X 6.4]  
 3 HOLES IN PANEL 120° APART ON A 1.25 [31.8] DIA. BOLT CIRCLE FOR #6 DIAL MTG. SCREWS  
 (4) STANDOFFS TAPPED 1/4-28 X .38 [9.5] DEEP FOR MTG. BOLTS  
 3.75 [95.3] DIA. DIAL PLATE GRADUATED (0-100)

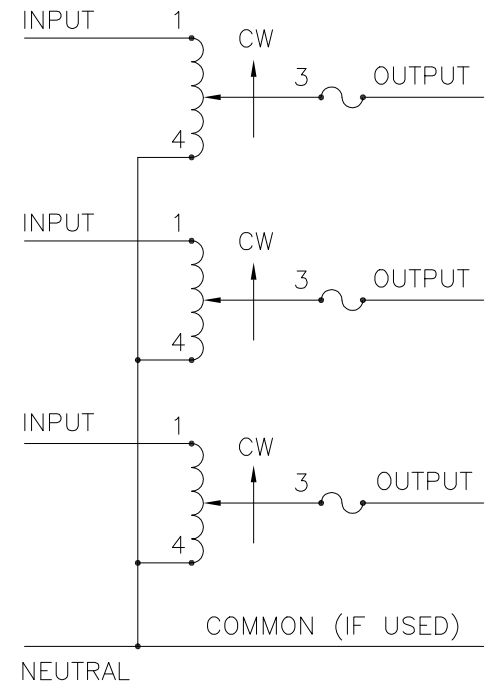

SCHMATIC  
 FUSE RECOMMENDED BUT NOT SUPPLIED

⌘ IF GANGED UNITS ARE USED IN A SYSTEM THAT ORDINARILY HAS A COMMON NEUTRAL OR GROUND BETWEEN SOURCE AND LOAD, THE NEUTRAL OR GROUND MUST BE CONNECTED TO THE COMMON TERMINALS OF THE VARIABLE TRANSFORMER ASSEMBLY. IF THE SYSTEM HAS NO NEUTRAL, THE LOAD MUST BE BALANCED OR THE TRANSFORMERS WILL BE DAMAGED.  
 ■ JUMPER PROVIDED IN STANDARD COMMON POSITION AND SHOULD BE MOVED OR REMOVED AS REQUIRED.  
 ++ LINE TO LINE VOLTAGE.

SPECIFICATIONS											
WIRING	INPUT		OUTPUT				SHAFT ROTATION TO INCREASE VOLTAGE	TERMINAL CONNECTIONS			
	VOLTS	HERTZ	VOLTS	CONSTANT CURRENT LOAD		CONSTANT IMPEDANCE LOAD		FOR INCREASING VOLTAGE AS VIEWED FROM BASE END ■			
				MAX. AMPS	MAX. KVA	MAX. AMPS		MAX. KVA	INPUT	JUMPER	OUTPUT
THREE PHASE WYE ⌘	240	60	0-240	12	4.96	15	6.24	CW	1-1-1	4-4-4	3-3-3
								CCW	4-4-4	1-1-1	3-3-3

UNLESS OTHERWISE SPECIFIED, TOLERANCE IS #				UNITS		TITLE: SPEC. CONTROL DRAWING					
DECIMALS	Holes	ANGLES	DRAFT	IN [mm]		SPEC. CONTROL DRAWING					
.XX	.0006	.002	1°	1-1/2°		MODEL: 1210B-3					
MATERIAL:				ALL DIMENSIONS APPLY AFTER PLATING		DRAWN BY: S.A. SMITH		DATE: 9/24/97		FIRST USED ON	
The information and design disclosed herein was originated by and is the property of STACO ENERGY PRODUCTS CO., which reserves all patent, proprietary, design, manufacturing, reproduction, use and sale rights thereto, and to any article disclosed therein except to the extent rights are expressly granted to others. The foregoing does not apply to vendor proprietary parts.				CHECKER:		DATE:		WEIGHT APPROX. 31 LBS		CODE IDENT. NO. 83008	
				ENGINEER:		DATE:		SCALE 1=1		SHEET 1 OF 1	
										DWG. NO. 031-2980	