

(4) HOLES FOR 1/2" DIA. MTG. BOLTS ON 10.75 X 8.25 CENTERS BOTTOM MTG. CHANNEL

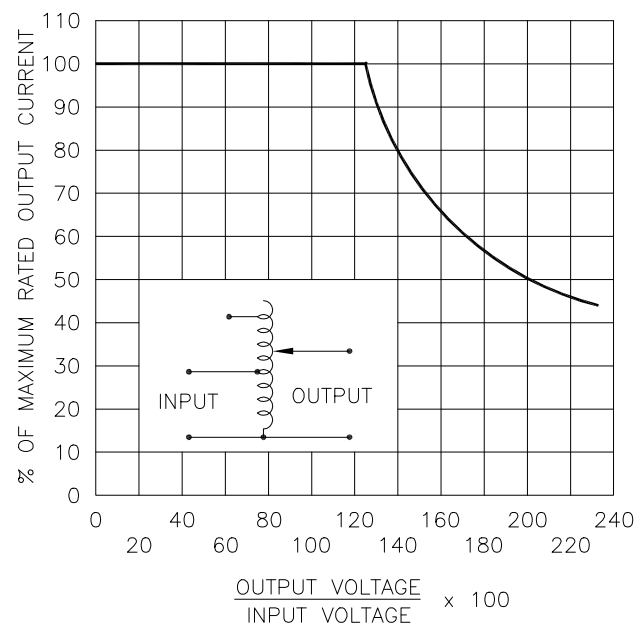
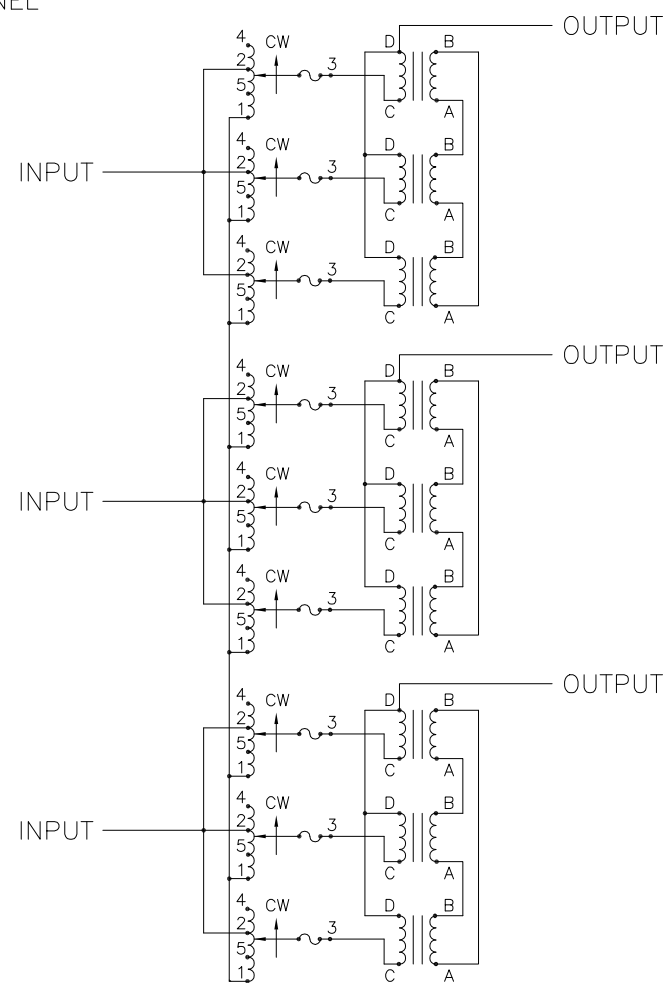

FIGURE A  
 MAXIMUM OUTPUT CURRENT OF ANY DUAL INPUT VOLTAGE OR VOLTAGE DOUBLER UNIT OPERATED AT LOWER INPUT VOLTAGE.



SCHEMATIC

\* MAXIMUM OUTPUT CURRENT IN OUTPUT VOLTAGE RANGE FROM 0 TO 25 PERCENT ABOVE LINE VOLTAGE. AT HIGHER OUTPUT VOLTAGES, OUTPUT CURRENT MUST BE REDUCED ACCORDING TO RATING CURVE (SEE FIGURE A).

\*\* MAXIMUM KVA AT MAXIMUM OUTPUT AND CORRESPONDING DE-RATED CURRENT. MAXIMUM KVA AT LOWER OUTPUT VOLTAGES MAY BE CALCULATED FROM RATING CURVE (SEE FIGURE A).

V.D. = VOLTAGE DOUBLER.

SPECIFICATIONS								
WIRING	INPUT		OUTPUT			SHAFT ROTATION FOR INCREASE VOLTAGE	TERMINAL CONNECTIONS	
	VOLTS	HERTZ	VOLTS	CONSTANT CURRENT LOAD			FOR INCREASING VOLTAGE AS VIEWED FROM ROTOR END	
THREE PHASE WYE	480	50/60	0-480	105	87.2	CW	4-4-4	D-D-D
			0-560	105	101.7		2-2-2	D-D-D
			0-560	* 105-45 V.D.	** 43.6		5-5-5	D-D-D

UNLESS OTHERWISE SPECIFIED, TOLERANCE IS #		UNITS		TITLE:		DRAWN BY		DATE		FIRST USED ON		DO NOT SCALE DWG.		CUSTOMER APPROVAL		DATE	
DECIMALS	Holes	ANGLES	DRAFT	IN	MM	SPEC. CONTROL DWG. MOTORIZED VARIABLE XFMR TYPE: 6020-9Y						TIM RAU		9/23/96			
.XX	.12	1°	1-1/2°			MATERIAL:		CHECKER		DATE		SCALE		.25=1		SHEET 1 OF 1	
The information and design disclosed herein was originated by and is the property of STACO ENERGY PRODUCTS CO., which reserves all patent, proprietary, design, manufacturing, reproduction, use and sale rights thereto, and to any article disclosed therein except to the extent rights are expressly granted to others. The foregoing does not apply to vendor proprietary parts.																	
STACO ENERGY PRODUCTS CO. A COMPONENTS CORPORATION OF AMERICA COMPANY DAYTON, OHIO U.S.A.																	
DWG. NO. 032-8207																	