

# MAXIMUM OUTPUT CURRENT IN OUTPUT VOLTAGE RANGE FROM 0 TO 25% ABOVE LINE VOLTAGE. AT HIGHER OUTPUT VOLTAGES, THE OUTPUT CURRENT MUST BE REDUCED ACCORDING TO THE DERATING CURVE FIGURE A.

§ MAXIMUM KVA AT MAXIMUM OUTPUT VOLTAGE AND CORRESPONDING DERATED OUTPUT CURRENT. MAXIMUM KVA FOR LOWER VOLTAGES MAY BE CALCULATED FROM DERATING CURVE FIGURE A.

++ LINE TO LINE VOLTAGE.

∏ IF GANGED UNITS ARE USED IN A SYSTEM THAT ORDINARILY HAS A COMMON NEUTRAL OR GROUND BETWEEN SOURCE AND LOAD, THE NEUTRAL OR GROUND MUST BE CONNECTED TO THE COMMON TERMINALS OF THE VARIABLE TRANSFORMER ASSEMBLY. IF THE SYSTEM HAS NO NEUTRAL, THE LOAD MUST BE BALANCED OR THE TRANSFORMER WILL BE DAMAGED.

■ JUMPER PROVIDED IN STANDARD COMMON POSITION AND SHOULD BE MOVED OR REMOVED AS REQUIRED.

+ MOTOR DRIVEN UNITS USE TERMINAL CONNECTIONS FOR CCW INCREASING VOLTAGE, AS VIEWED FROM THE BASE END.

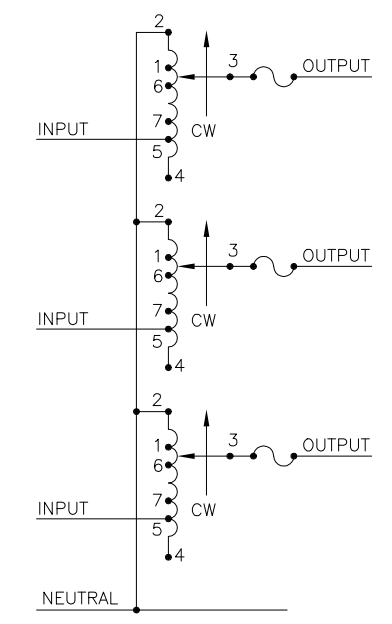

SCHEMATIC  
 THREE PHASE WYE  
 FUSES RECOMMENDED BUT NOT SUPPLIED

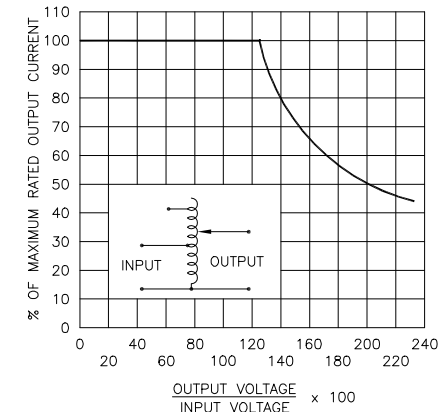
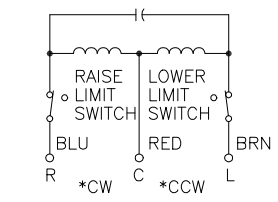

FIGURE A  
 MAXIMUM OUTPUT CURRENT OF ANY DUAL INPUT VOLTAGE OR VOLTAGE DOUBLER UNIT OPERATED AT LOWER INPUT VOLTAGE.



MOTOR CIRCUIT  
 120V, 50/60 HZ  
 \* ROTATION AS VIEWED FROM MOTOR END  
 MOTOR SPEED: SEE CHART

SPEED (SECONDS)	MODEL NUMBER
5	5M1520CT-3
15	15M1520CT-3
30	30M1520CT-3
60	60M1520CT-3

SPECIFICATIONS											
WIRING	INPUT		OUTPUT				SHAFT ROTATION TO INCREASE VOLTAGE	TERMINAL CONNECTIONS +			
	VOLTS	HERTZ	VOLTS	CONSTANT CURRENT LOAD MAX. AMPS	CONSTANT IMPEDANCE LOAD MAX. KVA	MAX. AMPS		MAX. KVA	FOR INCREASING VOLTAGE AS VIEWED FROM BASE END ■		
THREE PHASE WYE ∏	480 ++	50/60	0-480	9.5	7.90	12	10	CW	2-2-2	4-4-4	3-3-3
		60	0-560	9.5	9.21	—	—	CCW	4-4-4	2-2-2	3-3-3
	240 ++	60	0-560	9.5#	3.96§	—	—	CW	1-1-1	4-4-4	3-3-3
			0-560	9.5#	3.96§	—	—	CCW	5-5-5	2-2-2	3-3-3

UNLESS OTHERWISE SPECIFIED, TOLERANCE IS # DECIMALS .XX .0005 HOLES .01 ANGLES 1° DRAFT 1-1/2° UNITS IN [mm]

MATERIAL: ALL DIMENSIONS APPLY AFTER PLATING

TITLE: SPEC. CONTROL DRAWING VARIABLE TRANSFORMER MODEL: M1520CT-3

STACO ENERGY PRODUCTS CO. A COMPONENTS CORPORATION OF AMERICA COMPANY DAYTON, OHIO U.S.A.

DRAWN BY: S.A. SMITH DATE: 2/4/98 FIRST USED ON: DO NOT SCALE DWG. CUSTOMER APPROVAL: DATE:

CHECKER: DATE: WEIGHT APPROX. 76.5 LBS CODE IDENT. NO. 83008 DWG. NO. 031-4165

ENGINEER: DATE: SCALE .50=1 SHEET 1 OF 1