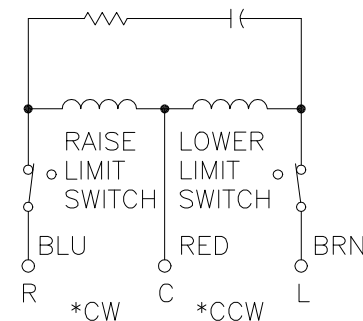

FIGURE A
 MAXIMUM OUTPUT CURRENT OF ANY
 DUAL INPUT VOLTAGE OR VOLTAGE DOUBLER
 UNIT OPERATED AT LOWER INPUT VOLTAGE.

* MAXIMUM OUTPUT CURRENT IN OUTPUT VOLTAGE RANGE FROM 0 TO 25% ABOVE LINE VOLTAGE. AT HIGHER OUTPUT VOLTAGES, OUTPUT CURRENT MUST BE REDUCED ACCORDING TO RATING CURVE, FIGURE A.

‡ MAXIMUM KVA AT MAXIMUM OUTPUT AND CORRESPONDING DE-RATED CURRENT. MAXIMUM KVA AT LOWER OUTPUT VOLTAGES MAY BE CALCULATED FROM RATING CURVE, FIGURE A.

V.D. = VOLTAGE DOUBLER.



120V, 50/60 HZ.
 * ROTATION AS VIEWED FROM MOTOR END
 SPEED: SEE CHART

MOTOR CIRCUIT

SPEED (SECONDS)	MODEL NUMBER	DIM "A"
5	5M5021-3P	25.56 [649.2]
15	15M5021-3P	27.38 [695.4]
30	30M5021-3P	27.38 [695.4]
60	60M5021-3P	27.38 [695.4]

WIRING	INPUT		OUTPUT			SHAFT ROTATION FOR VOLTAGE INCREASE	TERMINAL CONNECTIONS FOR INCREASING VOLTAGE AS VIEWED FROM TOP	
	VOLTS	HERTZ	VOLTS	CONSTANT CURRENT LOAD			INPUT	OUTPUT
				MAX. AMPS	MAX. KVA			
SINGLE PHASE PARALLEL	240	50/60	0-240	84	20.2	CW	1-4	1-D
			0-280	84	23.5		1-2	1-D
	120	50/60	0-280	84-36 V.D.	10.2 ‡	CW	1-5	1-D

UNLESS OTHERWISE SPECIFIED, TOLERANCE IS * DECIMALS .XX .XXX .12 .000 .03 .1° .1-1/2°

MATERIAL: ALL DIMENSIONS APPLY AFTER PLATING

TITLE: SPEC. CONTROL DRAWING VARIABLE MOTORIZED XFMR. TYPE: M5021-3P
 STACO ENERGY PRODUCTS CO. A COMPONENTS CORPORATION OF AMERICA COMPANY DAYTON, OHIO U.S.A.

DRAWN BY: TIM RAU DATE: 3/11/98 FIRST USED ON: DO NOT SCALE DWG. CUSTOMER APPROVAL: DATE:
 CHECKER: DATE: WEIGHT APPROX. 237 LBS. CODE IDENT. NO. 83008 DWG. NO. 031-7680
 ENGINEER: DATE: SCALE .5=1 SHEET 1 OF 1